

Computer Graphics: 8-Hidden Surface Removal

Prof. Dr. Charles A. Wüthrich,
Fakultät Medien, Medieninformatik
Bauhaus-Universität Weimar
caw AT medien.uni-weimar.de

Depth information

- Depth information is an important clue to our visual system
- It allows us to discern which objects are in front, and which ones are behind
- The challenge is to know which are the closest objects to the viewer
- Basically, it is a 2-dimensional sorting problem!

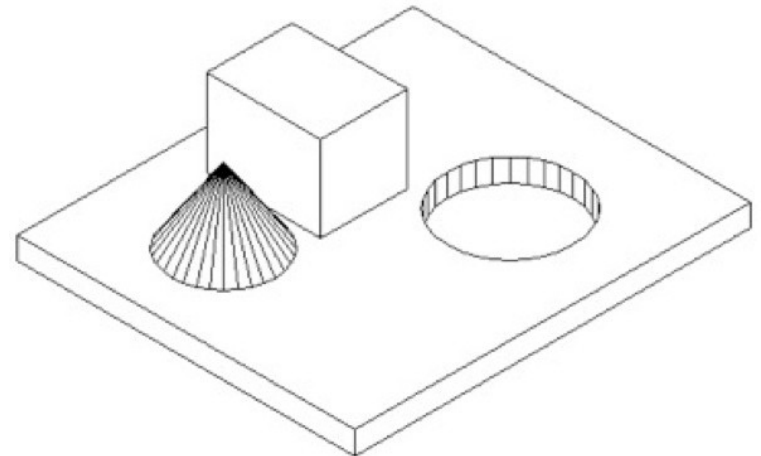
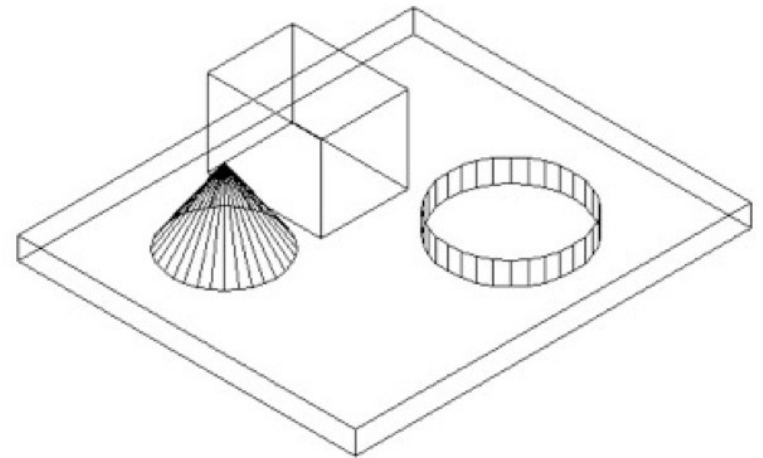

Introduction on hidden surface removal

- Problem: which elements in a picture are not hidden by other ones?

- Two main classes of algorithms

- Object precision:
based on objects

```
for each object DO
  compute non-hidden
  parts
  draw them on screen
END
```

- Image precision:
based on pixels

```
for each pixel DO
  search object closest
  to screen
  draw corresp. colour
end
```

- Trivial algorithm:
compare all polygons
with each other

Back face culling

- Of all the faces of an object, only the ones facing the viewer need to be rendered to the screen
- This reduces the number of polygons to be rendered by ca. one half
- The test to perform is easy if the normals to the polygon are available
- The scalar product $V \times N$ must be negative

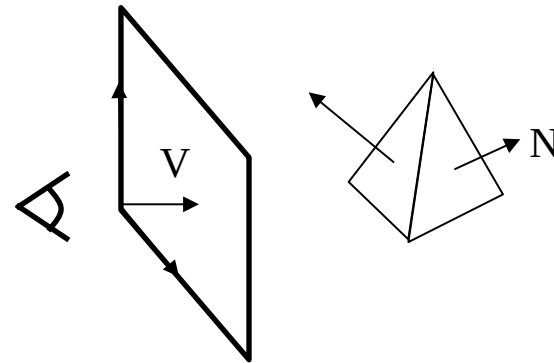

- Note that the test can be easily done by computing the z coordinate of N in screen coordinate space
- Even easier, looking if the polygon vertices lies clockwise produces the same result

HSR: Painter's algorithm

- Ever saw a painter compose a picture?
 - He starts painting the background
 - And proceeds to the foremost
- This is how the painter algorithm works:
 - Sort polygons by decreasing z_{\max}
 - Draw polygons from maximum z to minimum z

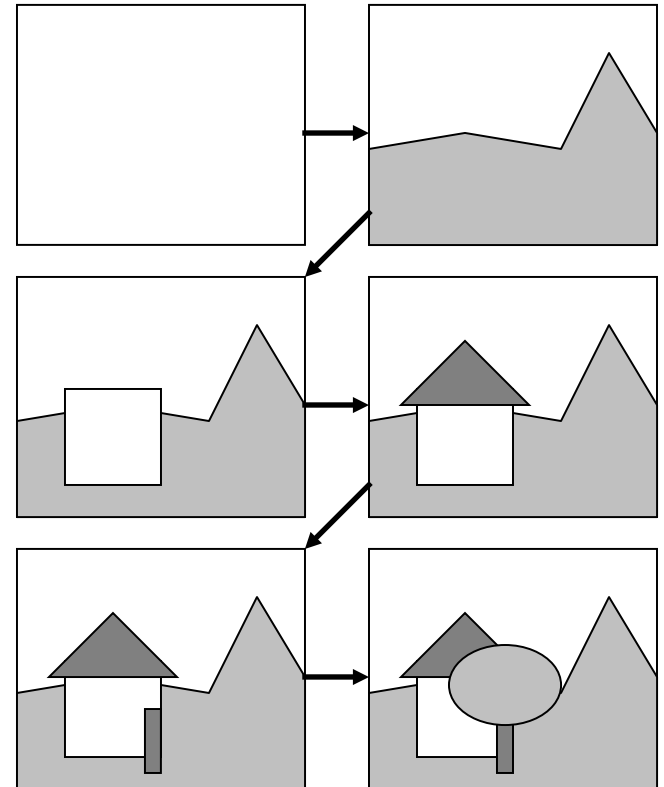

HSR: Painter's algorithm

- Ever saw a painter compose a picture?
 - He starts painting the background
 - And proceeds to the foremost
- This is how the painter algorithm works:
 - Sort polygons by decreasing z_{\max}
 - Draw polygons from maximum z to minimum z
- Unfortunately, there are cases when the algorithm does not work

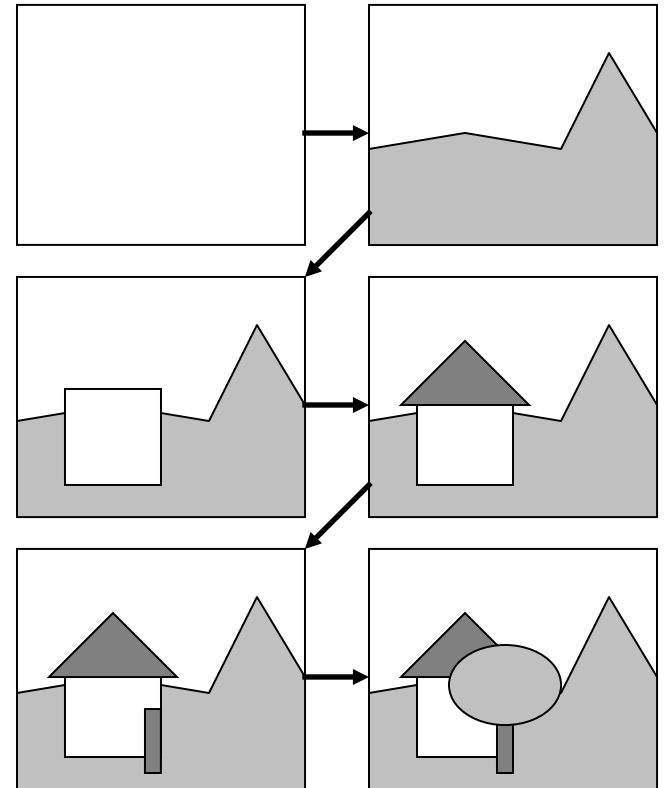

HSR: Painter's algorithm

- And which cases are they?
 - Here P_2 partially covers P_1 , but since z_{\max} in P_2 is bigger than the one on P_1 , P_1 gets drawn over P_2
- The Painter algorithm can be modified to work in all cases

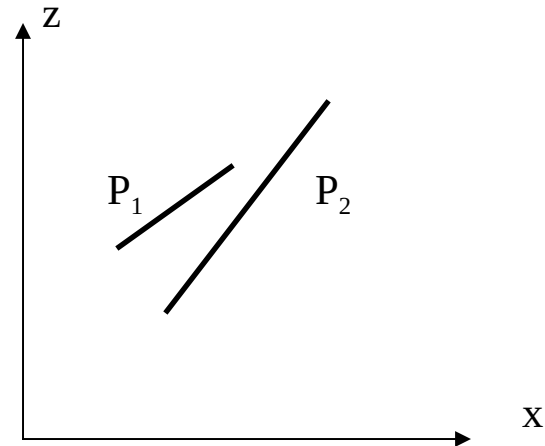

HSR: Painter's algorithm

- Problems occur when their z domains overlap
- One can store z_{\max} and z_{\min} for each polygon and then compare
- If they overlap, then a number of cases allow to draw P_1
 1. x axis proj. do not overlap
 2. y axis proj. do not overlap
 3. xy plane projection does not overlap (use bounding rectangles to overlap)
 4. P_1 lies on opposite side of P_2 plane WRT viewpoint (replace pt. + VP coords. in plane eq.)
 5. P_2 lies on same side of P_1 plane WRT viewpoint

If one of these occurs, then polygon P_1 & P_2 can be drawn

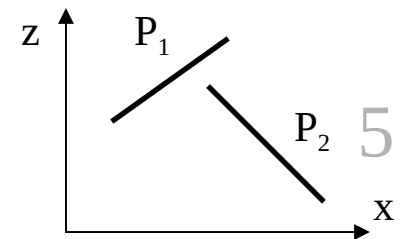
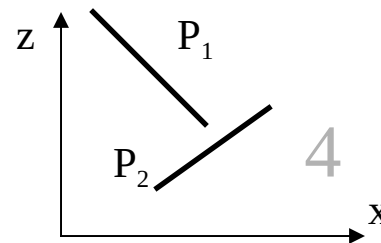
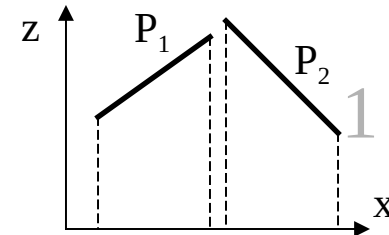
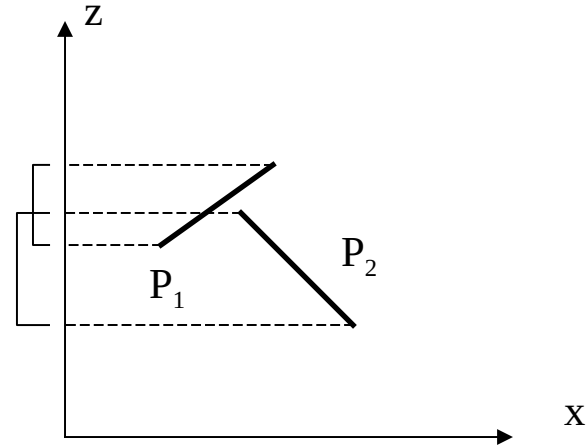

HSR: Painter's algorithm

- If none of the cases is true, then P_1 and P_2 are swapped and tests 4 and 5 are repeated
 - In this case P_1 is drawn in front of P_2
- There are still some ambiguous cases remaining:
 - If polygons partially overlap, then one of them must be split by using the plane of the other one
 - Cyclic overlappings, these generate infinite loops. Solution here is to remember when a cycle is done and split (by marking polygons)

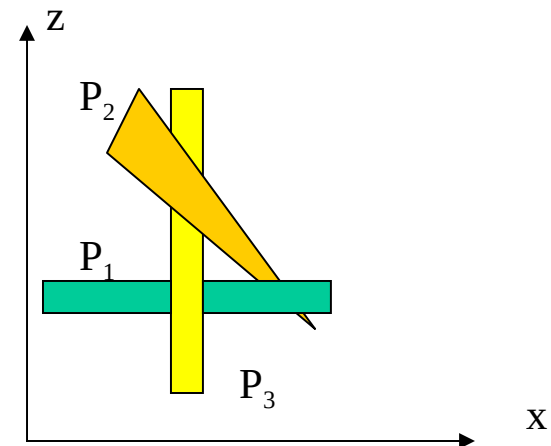
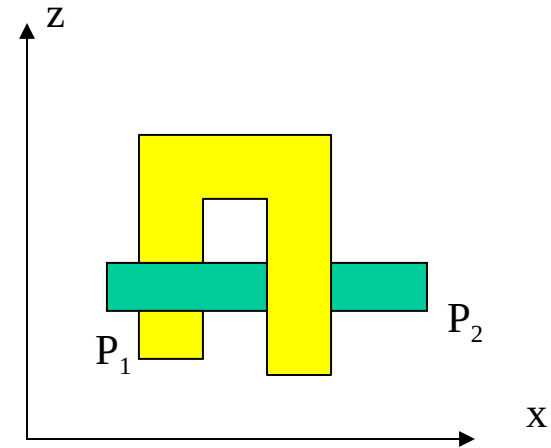

Z-Buffering (1)

- Z-buffering is easy to combine with the Scanline Algorithm
- Image Space Algorithm
- Idea: For every pixel on the screen, an additional variable is saved containing the depth value at that pixel
- The buffer of the additional variables is called the Z-buffer
- Whenever a polygon has to be drawn, the depth value of the pixel on the polygon is tested against the content of the Z-buffer to see if the new pixel must be drawn or not

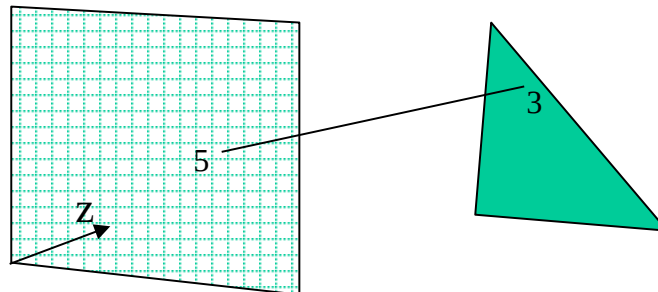

Z-Buffering (2)

- Algorithm:
 - Write $+\infty$ in every position of the Z-buffer (max. distance from the screen)
 - Compute for each pixel that is being scan-converted its depth at the z axis.
 - If $z < z_{buf}$ draw pixel and update the Z-buffer with the depth value of the pixel.
- Note that the same algorithm works also for any kind of surfaces, as long as the z value of the surface is computable

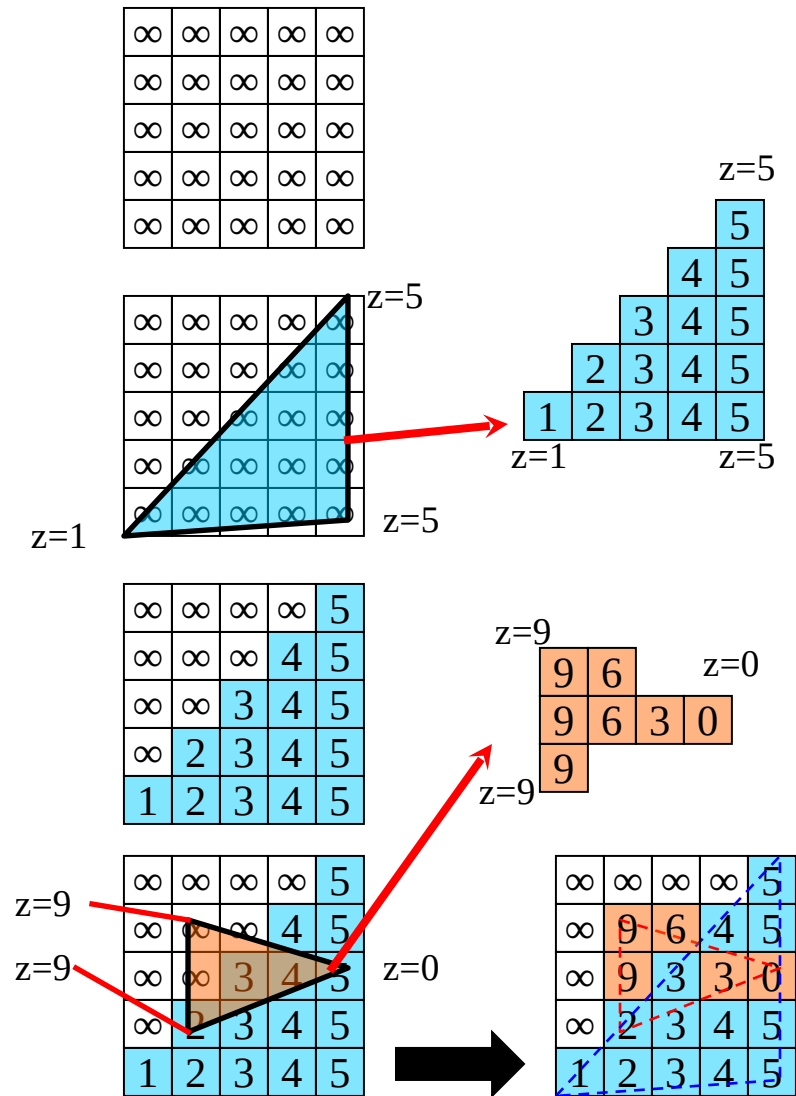

Z-Buffering (3)

- But how do I compute the Z-values of the polygon?
 - The computation can be done on the fly, while proceeding in the scanline algorithm
 - Remember the plane equation of a polygon:

$$Ax + By + Cz + D = 0$$
$$\Rightarrow z = \frac{-D - Ax - By}{C}$$

Z-Buffering (4)

- The scanline algorithm draws horizontally lines (x, x+1, ...)
- Suppose you know the z value of the polygon at the point (x,y)

$$z_1 = P(x, y)$$

Then you have that by moving to the right with an increment of Δx along the x-axis one obtains

$$P(x + \Delta x, y) = z_1 - (A/C) \Delta x$$

Since the increment is exactly one on the x axis we obtain

$$P(x + 1, y) = z_1 - (A/C)$$

- This is the increment that has to be added for passing from one pixel to the next to its right

Z-Buffering (5)

- Similarly the increment for computing z while passing from the scanline y to the next scanline can be derived:

$$z_1 = P(x, y)$$

By moving downwards with an increment of Δy along the y -axis one obtains

$$P(x, y + \Delta y) = z_1 - (B/C) \Delta y$$

Since the increment is exactly one on the y axis we obtain

$$P(x, y + 1) = z_1 - (B/C)$$

- This is the increment that has to be added for passing from one scanline to the next one vertically
- Obviously, one has to backtrack the scanline until the left edge of the polygon is reached

Z-Buffering (6)

- **Algorithmus:**

```
Initialize Z-Buffer with  $\infty$ 
For all Polygons P
  For each Pixel in P (obtained by scan conversion)
    Compute Zpoly = P(x,y)
    Zbuffer = read_z_buffer(x,y)
    if Zpoly < Zbuffer
      Draw_Pixel_to_Framebuffer(x,y,color)
      Set_Z_Buffer(x,y,Zpoly)
    end if
  end for
end for
```

Z-Buffering (7)

- Here a scene rendered with z-buffering
- In the lower pictures, the z-buffer values are rendered
 - white=far
 - black=near

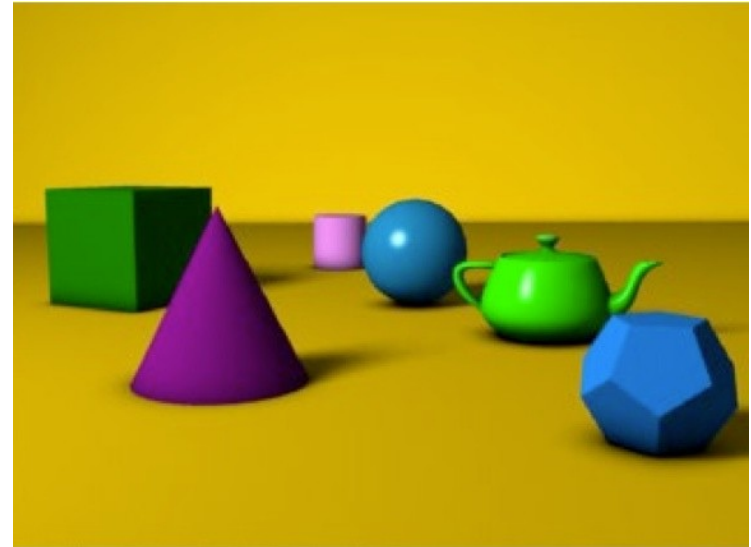

Area Subdivision - Warnock (1)

- A second class of algorithms uses space partitioning to reduce the complexity
- Such algorithms use a divide and conquer strategy to solve the problem
- The underlying idea is simple:
 - Subdivide the projection plane in smaller regions
 - Polygons are sorted to their relevant region
 - The problem is recursively subdivided until a simple solution can be found
 - The smaller the subdivision region, the less polygons have to be handled, and the easier the decision to be made
- Given a polygon, and a region, four cases are possible:

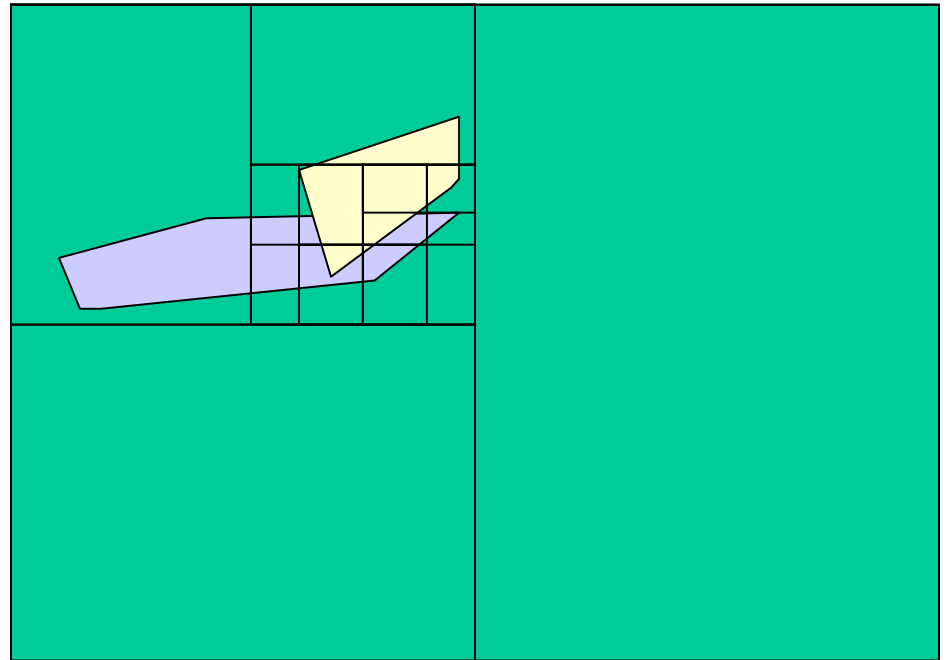

Area Subdivision - Warnock (2)

Given a region R , and a polygon P , 4 cases are possible:

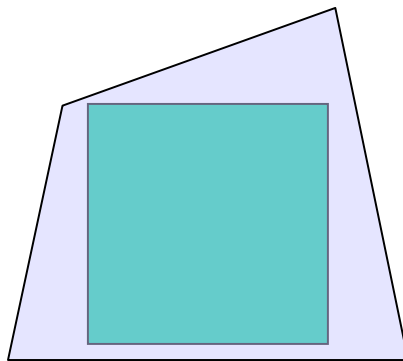

(a) Covering

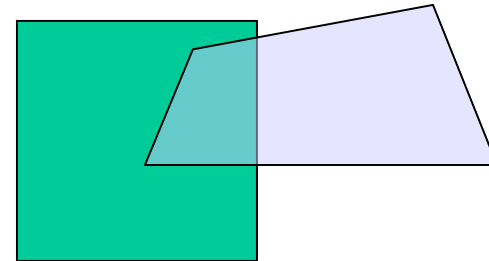

(b) Intersecting

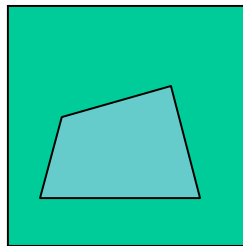

(c) Inside

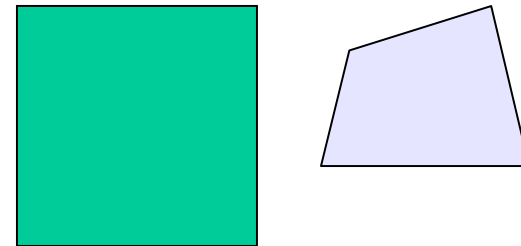

(d) Outside

Area Subdivision - Warnock (3)

Given a region R, four cases are possible:

1. all polygons lie outside R
→ Draw R with the background colour
2. Only one polygon intersects or is inside R
→ Draw first background color, then draw the polygon
3. A single polygon covers completely R
→ Draw R in the colour of the polygon
4. More than one polygon intersects R, but one of these polygons covers the whole regions and is in front
→ Draw R in the colour of the surrounding polygon

Area Subdivision - Warnock (4)

- How do I test the last condition?
 - Compute all z coordinates of the planes of the relevant polygons for the region R at the corner points of the region
 - If one of the polygon has all z values at the corners in front of the other polygons relevant to the region, then draw this polygon
- If none of these case occur, then subdivide region further
- Until when?
 - Until the region R is as big as a pixel
 - In this case the colour of the pixel will be set to the colour of the polygon that is in front at the middle point of the pixel (by evaluating z at the centre of the pixel for each polygon)
 - Alternatively, one can subdivide at sub-pixel level and do a mean of the values found at subpixel level

Binary Space Partition trees (1)

- BSP trees are efficient algorithms in the case of a moving viewpoint in a static environment
 - For ex. computer games like flight simulators
- The idea: the polygon planes are used to subdivide the region into two subspaces
 - one corresponding to the front
 - one to the back of the polygon
- Subspaces are recursively subdivided until they contain only one polygon
- This achieves a binary tree with single polygons as leaves, and mid nodes splitting planes
- Given a viewpoint V , correct polygon painting can be done by traversing the tree in an in-order fashion, and drawing polygons as encountered.
- This corresponds to implementing that a polygon will be scan-converted correctly if
 - all polygons on the other side of it from the viewer are scan converted
 - then the polygon itself
 - then the ones on the side of the viewer

How to build the BSP tree

- Choose one polygon, consider its plane and sort remaining polygons in
 - back polygons
 - front polygons
- Decide by substituting in equation
- If a polygon belongs to both, split it into 2 subpolygons
- Redo the splitting on the subspaces obtained
- Continue splitting till each subdivision has only one element
- First we pick one arbitrary polygon, e.g. 3

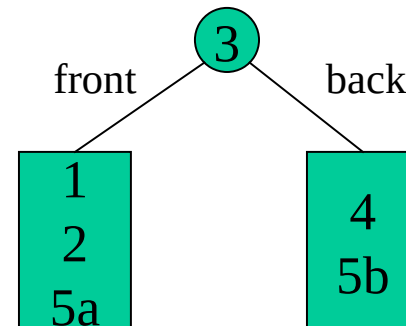
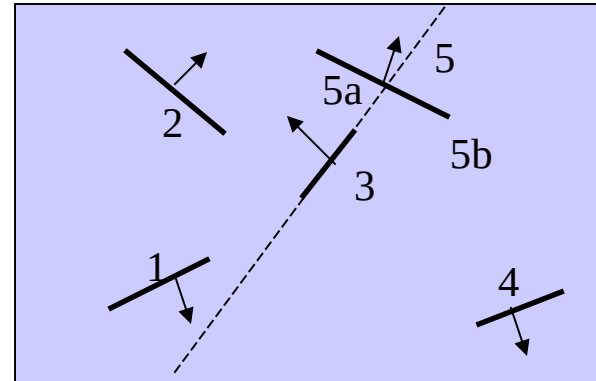

How to build the BSP tree

- repeat process until one polygon only in subspace

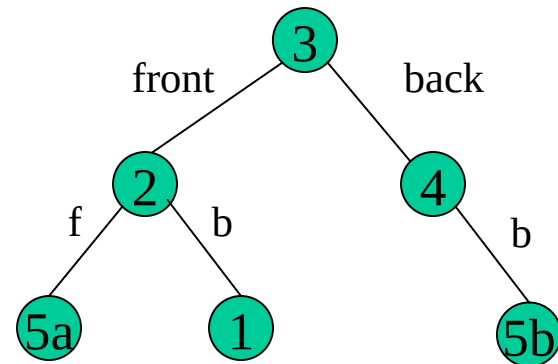
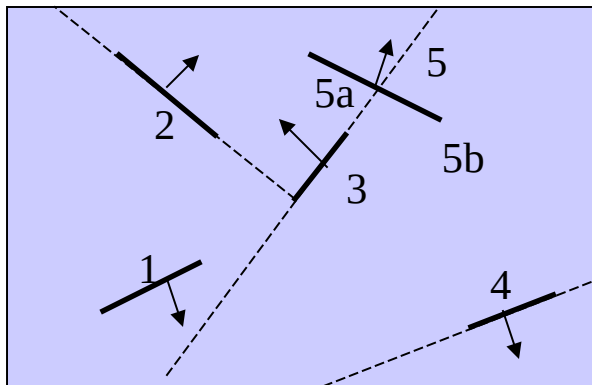
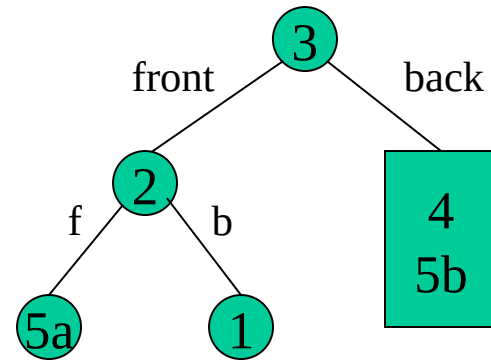
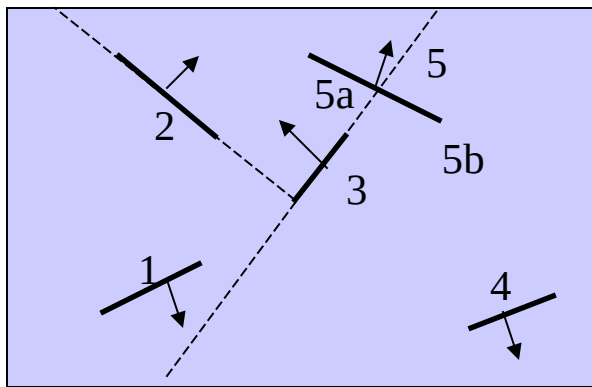

How to render from the BSP tree

- Given tree and viewpoint V, it suffices to render the polygons in the correct order
 - If V is in front space of root polygon
 - display first rear polygons
 - display root polygon
 - display front polygons
 - do it recursively for all subspaces till leaves are reached
 - If V in rear space, display in the order front, root, rear
 - If poly is seen on edge, then either order will be okay
 - Note that V coords. can be substituted in plane eq to decide the front rear question
 - This decision has to be taken at EACH node!!!!

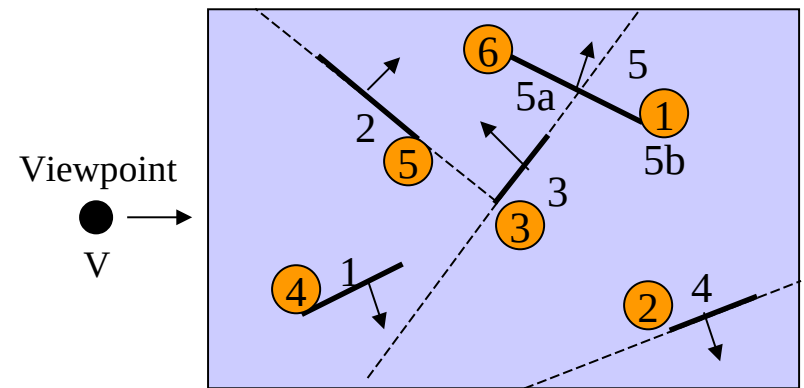
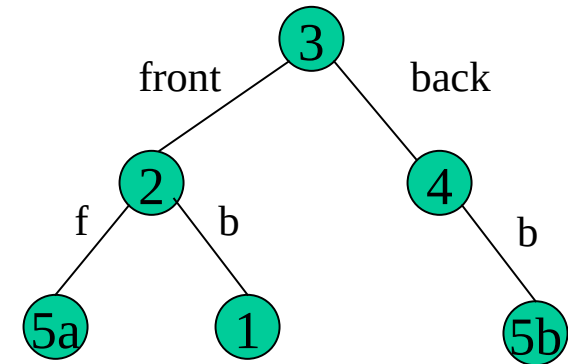

How to render from the BSP tree

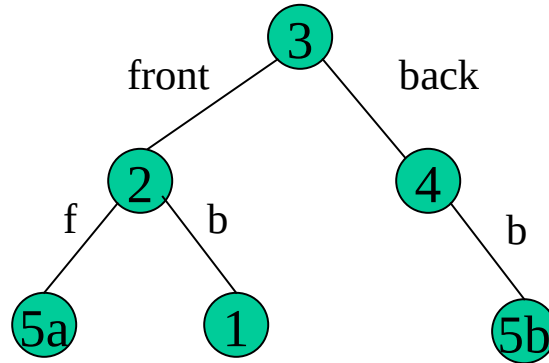

Front: rear, root, front

Rear:: front, root, rear

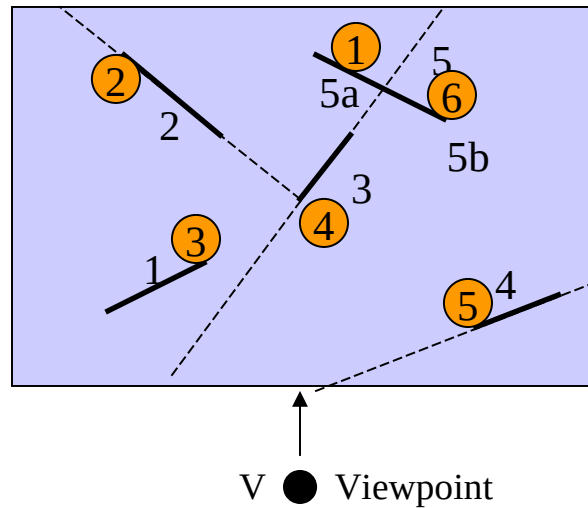

How to render from the BSP tree

- The advantage of this method is that the tree is traversed in linear time
- Once tree is built, it is easy to do visibility from a new point
- Tree needs no recomputing
- Algo can be modified to deal with non static scenes
- Backface culling can be done during rendering time, so that it is done on the fly
(front-rear test is all I need to decide backfaces)

Some speed considerations

Relative Performance

Algo	Polygons in the scene		
	100	2500	60000
Painter	1	10	507
Z-Buffer*	54	54	54
Warnock	11	64	307

nach Foley, van Dam, Table 15.3, S. 716

Z-Buffer - Abschätzung ist konstant, weil die Erhöhung der Polygonanzahl in der Regel dazu führt dass die mittl. Polygongröße kleiner wird. Das Produkt aus Polygonanzahl und Pixel je Polygon bleibt somit konstant.

End considerations

- Depth Sort: efficient for few polygons
- Z-Buffer: constant performance, but needs additional buffer
- Warnock: efficient for many polygons
- BSP trees, convenient when viewpoint moves and not the scene

End

+++ Ende - The end - Finis - Fin - Fine +++ Ende - The end - Finis - Fin - Fine +++